

*Journal of*

---

# **INDUSTRIAL TECHNOLOGY**

---

*Volume 15, Number 1 - November 1998 to January 1999*

---

## ***Surface Roughness Prediction Technique For CNC End-Milling***

*By Dr. Mike S. Lou, Dr. Joseph C. Chen & Dr. Caleb M. Li*

**KEYWORD SEARCH**

***Materials & Processes  
Quality Control  
Manufacturing***

*Reviewed Article*

---

*The Official Electronic Publication of the National Association of Industrial Technology*

© 1998

---



Dr. Mike S. Lou is an associate professor in the Department of Electronic Engineering at Cheng-Shiu Junior College of Technology and Commerce, Kaohsiung, Taiwan. His research field includes microprocessor control, interface control, neural fuzzy system, and engineering education.



Dr. Joseph C. Chen, PE is an assistant professor in the Department of Industrial Education and Technology at Iowa State University. Recently, he received Early Achievement in Teaching Award from the Iowa State University. His research interests are in cellular manufacturing systems, machine tool dynamics, and intelligent control as it relates to neural networks and fuzzy control.



Dr. Caleb M. Li is an Associate Professor in the Department of Industrial Engineering at Feng Chia University, Taiwan. His research interests are robust design, experimental design and quality control for industrial applications.

# Surface Roughness Prediction Technique For CNC End-Milling

By Dr. Mike S. Lou, Dr. Joseph C. Chen & Dr. Caleb M. Li

less operator input, provide greater improvements in productivity, and increase the quality of the machined part.

Among several CNC industrial machining processes, milling is a fundamental machining operation. End milling is the most common metal removal operation encountered. It is widely used in a variety of manufacturing industries including the aerospace and automotive sectors, where quality is an important factor in the production of slots, pockets, precision molds and dies. The quality of the surface plays a very important role in the performance of milling as a good-quality milled surface significantly improves fatigue strength, corrosion resistance, or creep life. Surface roughness also affects several functional attributes of parts, such as contact causing surface friction, wearing, light reflection, heat transmission, ability of distributing and holding a lubricant, coating, or resisting fatigue. Therefore, the desired finish surface is usually specified and the appropriate processes are selected to reach the required quality.

Several factors will influence the final surface roughness in a CNC milling operation. The final surface roughness might be considered as the sum of two independent effects: 1) the ideal surface roughness is a result of the geometry of tool and feed rate and 2) the natural surface roughness is a result of the irregularities in the cutting operation [Boothroyd & Knight, 1989]. Factors such as spindle speed, feed rate, and depth of cut that control the cutting operation can be setup in advance. However, factors such as tool geometry, tool wear, chip loads and chip formations, or the material properties of both tool and workpiece are uncontrolled (Huynh & Fan, 1992). Even in the occurrence of chatter or

vibrations of the machine tool, defects in the structure of the work material, wear of tool, or irregularities of chip formation contribute to the surface damage in practice during machining (Boothroyd & Knight, 1989). One should develop techniques to predict the surface roughness of a product before milling in order to evaluate the fitness of machining parameters such as feed rate or spindle speed for keeping a desired surface roughness and increasing product quality. It is also important that the prediction technique should be accurate, reliable, low-cost, and non-destructive. Therefore, the purpose of this study is to develop one surface prediction technique which is termed the multiple regression prediction model and then evaluate its prediction ability.

## Literature Review

In order to develop a new technology for surface prediction, literature reviews of the surface texture, surface finish parameters, and multiple regression analysis have been carried out and summarized as follows:

### Surface Texture

The terms surface finish and surface roughness are used very widely in industry and are generally used to quantify the smoothness of a surface finish. In 1947, the American Standard B46.1-1947, "Surface Texture", defined many of the concepts of surface metrology and terminology which overshadowed previous standards. A few concepts are discussed and shown as follows [Brosheer, 1948; Hommel, 1988; Olivo, 1987; ASME, 1988]:

- Surface texture: Surface texture is the pattern of the surface which deviates from a nominal surface. The deviations may be

## Introduction

Intense international competition has focused the attention of manufacturers on automation as means to increase productivity and improve quality. To realize full automation in machining, computer numerically controlled (CNC) machine tools have been implemented during the past decades. CNC machine tools require

repetitive or random and may result from roughness, waviness, lay, and flaws.

- **Real surface:** The real surface of an object is the peripheral skin which separates it from the surrounding medium. This surface invariably assimilates structural deviations which are classified as form errors, waviness, and surface roughness.
- **Roughness:** Roughness consists of the finer irregularities of the surface texture, usually including those irregularities that result from the inherent action of the production process. Profiles of roughness and waviness are shown in Figure 1.
- **Roughness width:** Roughness width is the distance parallel to the nominal surface between successive peaks or ridges which constitute the predominant pattern of the roughness.
- **Roughness width cutoff:** Roughness width cutoff is included in the measurement of average roughness height which denotes the greatest spacing of repetitive surface irregularities. It is rated in thousandths of an inch. Standard tables list roughness width cutoff values of 0.003, 0.10, 0.030, 0.100, 0.300 and 1.000 inches. If no value is specified, a rating of 0.030" is assumed.
- **Waviness:** Waviness should include all irregularities whose spacing is greater than the roughness sampling length and less than the waviness sampling length.
- **Waviness height:** Waviness height is the peak-to-valley distance which is rated in inches.
- **Waviness width:** Waviness width is the spacing of successive wave peaks or successive wave valleys which is rated in inches.
- **Lay:** Lay is the direction of the predominant surface pattern, normally determined by the production method.
- **Flaws:** Flaws are unintentional, unexpected, and unwanted

interruptions in the topography typical of a part surface.

- **Roughness sampling length:** The roughness sampling length is the sampling length within which the roughness average is determined. This length is chosen, or specified, to separate the profile irregularities which are designated as roughness from those irregularities designated as waviness.

**Surface Finish Parameters**

Surface finish could be specified in many different parameters. Due to the need for different parameters in a wide variety of machining operations, a large number of newly developed surface roughness parameters were developed. Some of the popular parameters of surface finish specification are described as follows:

- **Roughness average (R<sub>a</sub>):** This parameter is also known as the arithmetic mean roughness value, AA (arithmetic average) or CLA (center line average). R<sub>a</sub> is universally recognized and the most used international parameter of roughness. Therefore,

$$R_a = \frac{1}{L} \int_0^L |Y(x)| dx \quad (1)$$

where R<sub>a</sub> = the arithmetic average deviation from the mean line  
 L = the sampling length  
 y = the ordinate of the profile curve

It is the arithmetic mean of the departure of the roughness profile from the mean line. An example of the surface profile is shown in Figure 2.

- **Root-mean-square (rms) roughness (R<sub>q</sub>):** This is the root-mean-square parameter corresponding to R<sub>a</sub>:

$$R_q = \sqrt{\left[ \frac{1}{L} \int_0^L (Y(x))^2 dx \right]} \quad (2)$$

- **Maximum peak-to-valley roughness height (R<sub>y</sub> or R<sub>max</sub>):** This is the distance between two lines parallel to the mean line that contacts the extreme upper and lower points on the profile within the roughness sampling length.

Since R<sub>a</sub> and R<sub>q</sub> are the most widely used surface parameters in industry, R<sub>a</sub> was selected to express the surface roughness in this study.

**Multiple Regression Analysis**

Since multiple regression is used to determine the correlation between a criterion variable and a combination of predictor variables, the statistical multiple regression method is applied. It can be used to analyze data from any of the major quantitative research designs such as causal-comparative, correctional, and experimental. This method is also able to handle interval, ordinal, or categorical data and provide estimates both of the magnitude and statistical significance of the relationships between variables [Gall & Borg,

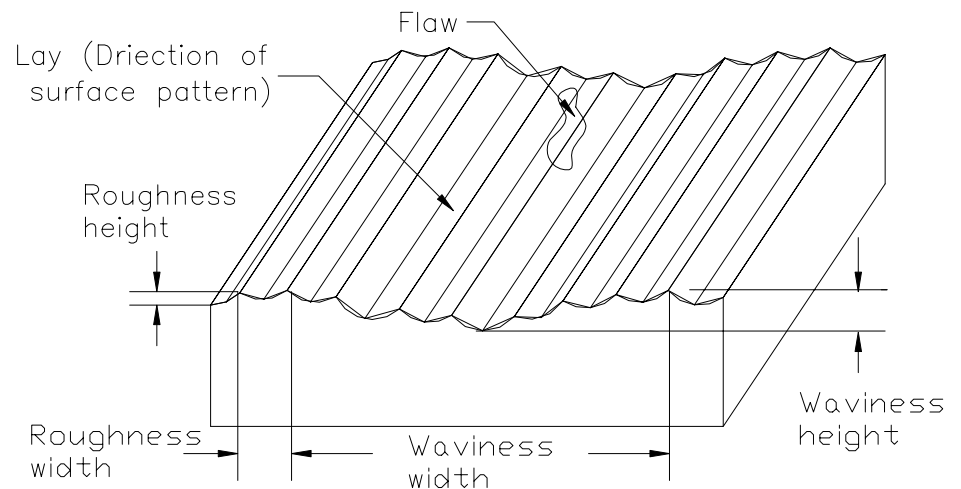

Figure 1. Roughness and waviness profiles

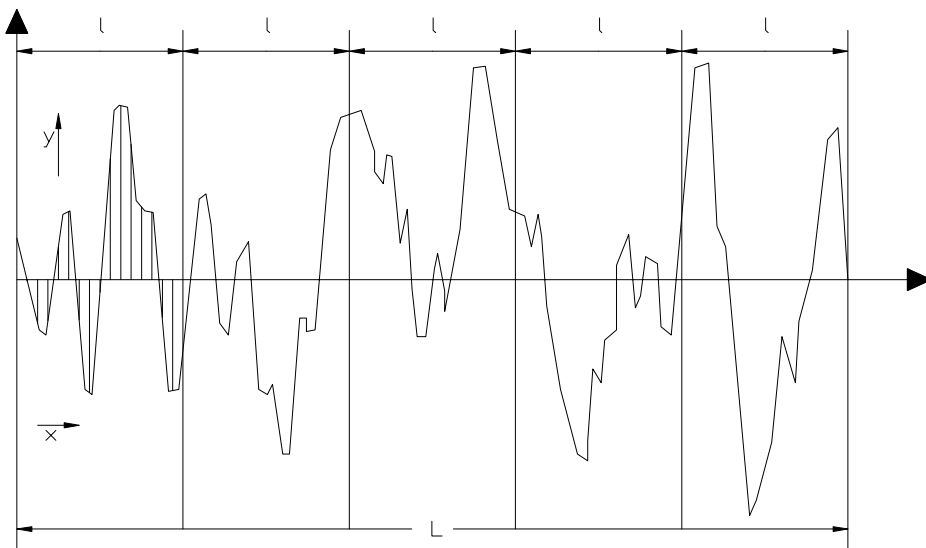

Figure 2. Profile of surface texture

1996]. Therefore, multiple regression analysis will be useful to predict the criterion variable finish surface roughness via predictor variables such as feed rate, spindle speed, or depth of cut.

### Multiple Regression Prediction Model

The proposed multiple regression model is a three-way interaction equation:

$$Y_i = \alpha_i + \beta_1 X_{1i} + \beta_2 X_{2i} + \beta_3 X_{3i} + \beta_4 X_{1i} X_{2i} + \beta_5 X_{1i} X_{3i} + \beta_6 X_{2i} X_{3i} + \beta_7 X_{1i} X_{2i} X_{3i} \quad (3)$$

- Where  $Y_i$ : surface roughness  $R_a$  (micro inch)
- $X_{1i}$ : spindle speed (revolutions per minute)
- $X_{2i}$ : feed rate (inch per minute)
- $X_{3i}$ : depth of cut (inch)

In this model, the criterion variable is the surface roughness ( $R_a$ ) and the predictor variables are spindle speed, feed rate, and depth of cut. Because these variables are controllable machining parameters, they can be used to predict the surface roughness in milling which will then enhance product quality.

### Experimental Design

The experiment was tested by using a Fadal CNC vertical machining center. According to the acceptable ranges of cutting speed, feed rate, and depth of cut when cutting 6061 aluminum one inch cubic block with a four-flute high speed steel cutter as shown

in Figure 3, four levels of spindle speed - 750, 1000, 1250, and 1500 revolutions per minute (rpm), seven levels of feed rate - 6, 9, 12, 15, 18, 21 and 24 inch per minute (ipm), and three levels of depth of cut - 0.01, 0.03, and 0.05 inch (in) were determined. The surface roughness ( $R_a$ ) was measured in micro inches (min) by a stylus-based profilometer. All of the machining parameters and the measured  $R_a$  were shown in Table 1.

Since the independent variables of this study were spindle speed, feed rate, and depth of cut, the dependent variable was the surface roughness ( $R_a$ ). The full regression model containing all the main effects and interactions terms was listed in equation (3). The general null hypotheses was described as the effects of spindle speed, feed rate, and depth of cut on the surface roughness do not significantly differ from zero; that is,

$$H_o: \beta_j = 0, \quad \text{where } j = 1, 2, 3, \dots, 7$$

The alternative hypothesis could also be expressed as:

$$H_a: \text{at least one of the } b_j \text{ not equal to zero.}$$

A commercial statistical package (SPSS) was used to do the regression analysis. A stepwise solution was selected to further reduce the number of variables. Predictor variables were entered one at a time, but could be

deleted if they did not contribute significantly to the regression when considered in combination with newly entered predictors.

In order to judge the accuracy of the multiple regression prediction model, percentage deviation ( $\phi_i$ ) and average percentage deviation ( $\bar{\phi}$ ) were used and defined as

$$\phi_i = \frac{|Ra'_i - \hat{Ra}_i|}{Ra'_i} \times 100\% \quad (4)$$

- where  $\phi_i$ : percentage deviation of single sample data
- $Ra'_i$ : actual  $R_a$  measured by a profilometer
- $\hat{Ra}_i$ : predicted  $R_a$  generated by a multiple regression equation

$$\bar{\phi} = \frac{\sum_{i=1}^m \phi_i}{m} \quad (5)$$

- where  $\bar{\phi}$ : average percentage deviation of all sample data
- $m$ : the size of sample data

This method would test the average percentage deviation of actual  $R_a$  (measured by an off-line stylus type profilometer) and predicted  $R_a$  (produced by the multiple regression model) as well as its ability to evaluate the prediction of this model.

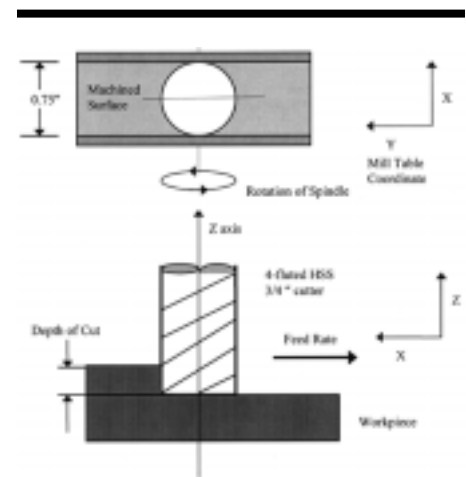

Figure 3. Cutting Geometry

| F \ S \ D | 6 ipm |      |      | 9 ipm |      |      | 12 ipm |      |      | 15 ipm |      |      |
|-----------|-------|------|------|-------|------|------|--------|------|------|--------|------|------|
|           | .01"  | .03" | .05" | .01"  | .03" | .05" | .01"   | .03" | .05" | .01"   | .03" | .05" |
| 750 rpm   | 65    | 63   | 72   | 109   | 99   | 95   | 144    | 102  | 94   | 125    | 122  | 104  |
| 1000 rpm  | 58    | 78   | 62   | 92    | 94   | 102  | 130    | 84   | 92   | 101    | 108  | 105  |
| 1250 rpm  | 62    | 63   | 71   | 79    | 81   | 92   | 101    | 99   | 85   | 106    | 96   | 96   |
| 1500 rpm  | 37    | 56   | 56   | 71    | 73   | 70   | 88     | 82   | 94   | 106    | 83   | 99   |

| F \ S \ D | 18 ipm |      |      | 21 ipm |      |      | 24 ipm |      |      |
|-----------|--------|------|------|--------|------|------|--------|------|------|
|           | .01"   | .03" | .05" | .01"   | .03" | .05" | .01"   | .03" | .05" |
| 750 rpm   | 185    | 147  | 121  | 178    | 163  | 150  | 187    | 170  | 172  |
| 1000 rpm  | 138    | 124  | 86   | 149    | 145  | 148  | 163    | 153  | 142  |
| 1250 rpm  | 115    | 92   | 95   | 125    | 100  | 105  | 155    | 109  | 121  |
| 1500 rpm  | 119    | 87   | 104  | 118    | 102  | 113  | 119    | 103  | 109  |

Note: 1. Feed rate (F): inch per minute (ipm)  
 2. Spindle speed (S): revolutions per minute (rpm)  
 3. Depth of cut (D): inch (in)  
 4. Surface roughness (Ra):micro inch (μ in)

Table 1. Experimental Design for Prediction Model (experimental data - unit: (m in))

### Experimental Results

After 84 specimens were cut for experimental purposes, they were measured off-line with a stylus type profilometer to obtain the roughness average value  $R_a$ . All original 84 samples as shown in Table 1 were randomly divided into two data sets - the training set and the testing set. The training set contained 60 samples which were used to build a prediction model and the testing set contained 24 samples which were used to test the flexibility of the prediction model as shown in Tables 2 and 3, respectively. Each sample consisted of four elements: spindle speed, feed rate, depth of cut, and measured surface roughness ( $R_a$ ).

A statistical model was created by regression function in SPSS from the training data set. The R Square was 0.86179 which showed that 86.17 % of the observed variability in  $R_a$  could be explained by the independent variables. The Multiple R was 0.92833 which meant that the correlation coefficient between the observed value of the dependent variable and the predicted value based on the regression model was high.

The value of F was 85.734 and the significance of F was zero in the ANOVA table as shown in Table 4. The null hypothesis shows there is no linear relationship between  $R_a$  and the independent variables. Thus, the independent variables were rejected.

At least one of the population regression coefficients was not zero.

In Table 5, the coefficients for the independent variables were listed in the column B. Using these coefficients, the multiple regression equation could be expressed as:

$$Y_i = 22.9468 + 10.9357X_{2i} - 0.004274X_{1i}X_{2i} + 0.674909X_{1i}X_{3i} - 69.7679X_{2i}X_{3i} \quad (6)$$

where  $Y_i$  was the predicted surface roughness  $R_a$ . It was also apparent that

feed rate ( $X_2$ ) was the most significant machining parameter to influence surface roughness ( $R_a$ ). The scatterplot between the observed  $R_a$  and the predicted  $R_a$  of all 84 samples as shown in Figure 4 indicated that the relationship between the actual  $R_a$  and the predicted  $R_a$  was linear.

The result of average percentage deviation ( $\bar{\phi}$ ) showed that the training data set (m=60) was 9.71% and the testing data set (m=24) was 9.97%. This means that the statistical model could predict the surface roughness ( $R_a$ ) with about 90.29% accuracy of the training data set and approximately 90.03% accuracy of the testing data set.

### Conclusions

The author examined a new approach for finish surface prediction in end-milling operations. Through experimentation, the system proved capable of predicting the surface roughness ( $R_a$ ) with about 90% accuracy. The important conclusion drawn from the present research was summarized as follows:

1. The surface roughness ( $R_a$ ) could be predicted effectively by applying spindle speed, feed rate, depth of cut, and their interactions in the multiple regression model.

| #  | Spindle Speed (rpm) | Feed Rate (ipm) | Depth of Cut (in) | Ra (μ in) | #  | Spindle Speed (rpm) | Feed Rate (ipm) | Depth of Cut (in) | Ra (μ in) |
|----|---------------------|-----------------|-------------------|-----------|----|---------------------|-----------------|-------------------|-----------|
| 1  | 1000                | 18              | 0.01              | 138       | 31 | 1000                | 6               | 0.05              | 62        |
| 2  | 1500                | 9               | 0.03              | 73        | 32 | 1500                | 21              | 0.05              | 113       |
| 3  | 1250                | 6               | 0.01              | 50        | 33 | 1250                | 12              | 0.01              | 101       |
| 4  | 750                 | 24              | 0.03              | 170       | 34 | 1000                | 12              | 0.01              | 130       |
| 5  | 1250                | 21              | 0.05              | 105       | 35 | 1250                | 18              | 0.05              | 95        |
| 6  | 750                 | 21              | 0.05              | 150       | 36 | 750                 | 9               | 0.03              | 99        |
| 7  | 1250                | 21              | 0.01              | 125       | 37 | 1500                | 24              | 0.03              | 103       |
| 8  | 1000                | 21              | 0.03              | 145       | 38 | 750                 | 6               | 0.03              | 63        |
| 9  | 1250                | 9               | 0.01              | 79        | 39 | 750                 | 21              | 0.03              | 163       |
| 10 | 1500                | 15              | 0.01              | 106       | 40 | 1500                | 24              | 0.01              | 119       |
| 11 | 1000                | 6               | 0.03              | 78        | 41 | 1500                | 24              | 0.05              | 109       |
| 12 | 750                 | 18              | 0.05              | 121       | 42 | 1250                | 9               | 0.03              | 81        |
| 13 | 1000                | 6               | 0.01              | 58        | 43 | 750                 | 6               | 0.01              | 65        |
| 14 | 1000                | 12              | 0.05              | 92        | 44 | 1000                | 21              | 0.01              | 149       |
| 15 | 1000                | 9               | 0.05              | 102       | 45 | 1250                | 18              | 0.01              | 115       |
| 16 | 1250                | 24              | 0.01              | 155       | 46 | 750                 | 12              | 0.03              | 102       |
| 17 | 750                 | 9               | 0.05              | 95        | 47 | 1250                | 6               | 0.05              | 71        |
| 18 | 1250                | 18              | 0.03              | 92        | 48 | 1250                | 15              | 0.03              | 96        |
| 19 | 1500                | 12              | 0.01              | 88        | 49 | 1250                | 9               | 0.05              | 92        |
| 20 | 1000                | 15              | 0.05              | 105       | 50 | 1250                | 6               | 0.03              | 63        |
| 21 | 1250                | 24              | 0.03              | 109       | 51 | 1500                | 18              | 0.01              | 119       |
| 22 | 750                 | 18              | 0.01              | 185       | 52 | 750                 | 15              | 0.05              | 104       |
| 23 | 1500                | 21              | 0.01              | 118       | 53 | 750                 | 12              | 0.05              | 94        |
| 24 | 750                 | 15              | 0.03              | 122       | 54 | 1500                | 6               | 0.01              | 37        |
| 25 | 1000                | 24              | 0.03              | 153       | 55 | 1250                | 21              | 0.03              | 100       |
| 26 | 1000                | 15              | 0.03              | 108       | 56 | 1000                | 24              | 0.01              | 163       |
| 27 | 750                 | 6               | 0.05              | 72        | 57 | 1000                | 15              | 0.01              | 101       |
| 28 | 1500                | 9               | 0.01              | 34        | 58 | 1250                | 12              | 0.05              | 85        |
| 29 | 750                 | 9               | 0.01              | 109       | 59 | 1500                | 15              | 0.05              | 99        |
| 30 | 1000                | 12              | 0.03              | 84        | 60 | 1500                | 18              | 0.05              | 104       |

Table 2. 60 Training Data Set

| #  | Spindle Speed (rpm) | Feed Rate (ipm) | Depth of Cut (in) | Ra (μ in) |
|----|---------------------|-----------------|-------------------|-----------|
| 1  | 1000                | 18              | 0.05              | 86        |
| 2  | 1500                | 6               | 0.05              | 56        |
| 3  | 750                 | 12              | 0.01              | 144       |
| 4  | 750                 | 18              | 0.03              | 147       |
| 5  | 1250                | 15              | 0.05              | 96        |
| 6  | 1000                | 9               | 0.01              | 92        |
| 7  | 1000                | 18              | 0.03              | 124       |
| 8  | 750                 | 24              | 0.05              | 172       |
| 9  | 1500                | 18              | 0.03              | 87        |
| 10 | 750                 | 24              | 0.01              | 187       |
| 11 | 1500                | 15              | 0.03              | 83        |
| 12 | 750                 | 15              | 0.01              | 125       |
| 13 | 1250                | 24              | 0.05              | 121       |
| 14 | 1250                | 15              | 0.01              | 106       |
| 15 | 1000                | 24              | 0.05              | 142       |
| 16 | 1500                | 12              | 0.05              | 94        |
| 17 | 1500                | 21              | 0.03              | 102       |
| 18 | 1250                | 12              | 0.03              | 99        |
| 19 | 1000                | 9               | 0.03              | 94        |
| 20 | 1500                | 12              | 0.03              | 82        |
| 21 | 750                 | 21              | 0.01              | 178       |
| 22 | 1500                | 6               | 0.03              | 56        |
| 23 | 1000                | 21              | 0.05              | 112       |
| 24 | 1500                | 9               | 0.05              | 70        |

Table 3. 24 Testing Data Set

- The multiple regression model could predict the surface roughness (Ra) with average percentage deviation of 9.71% or 90.29% accuracy from training data set.
- This multiple regression model could predict the surface roughness (Ra) from testing data set that was not included in the multiple regression analysis with average percentage deviation of 9.97% or accuracy of 90.03%.
- Feed rate was the most significant machining parameter used to predict the surface roughness in the multiple regression model.

The research to date has assumed that the cutting tools are identical in properties and the material of the workpiece is similar. Further research will consider different cutting tools and materials of the workpiece. In addition, artificial intelligent systems such as the fuzzy logic system or neural networks technique might be included to enhance the ability of the prediction system.

**References**

Boothroyd, G. and Knight, W. A., (1989), Fundamentals of Machining and Machine Tools, Second Edition, Marcel Dekker Inc., New York.  
 Brosheer, B. C., (1948), "How Smooth is Smooth? Part-I, Specification and Evaluation of Machined Finishes", American Machinist,

McGraw-Hill Publishing Company, pp. 97-112.

Gall, M., Borg, W. R., and Gall, J.P., (1996), Educational Research, Sixth Edition, Longman, New York.  
 Hommel Surface Roughness Terminology and Parameters, (1988), Hommel America, 30, Peter Court, New Britain, CT.  
 Huynh, V. M. and Fan, Y., (1992), "Surface-Texture Measurement and Characterization With Applications To Machine-Tool Monitoring", The International Journal of Advanced Manufacturing Technology, 7, pp.2-10.  
 Olivo, C. T., (1987), Machine Tool Technology and Manufacturing

Processes, C. Thomas Olivo Association, Albany, NY.

Publication Committee, (1988), Handbook of Industrial Metrology, American Society of Tool and Manufacturing Engineers, Prentice-Hall of India Private Limited, New Delhi, India.  
 Walker, J. R., (1989), Machining Fundamentals: from Basic to Advanced Techniques, The Goodheart-Willcox Company Inc., Illinois.

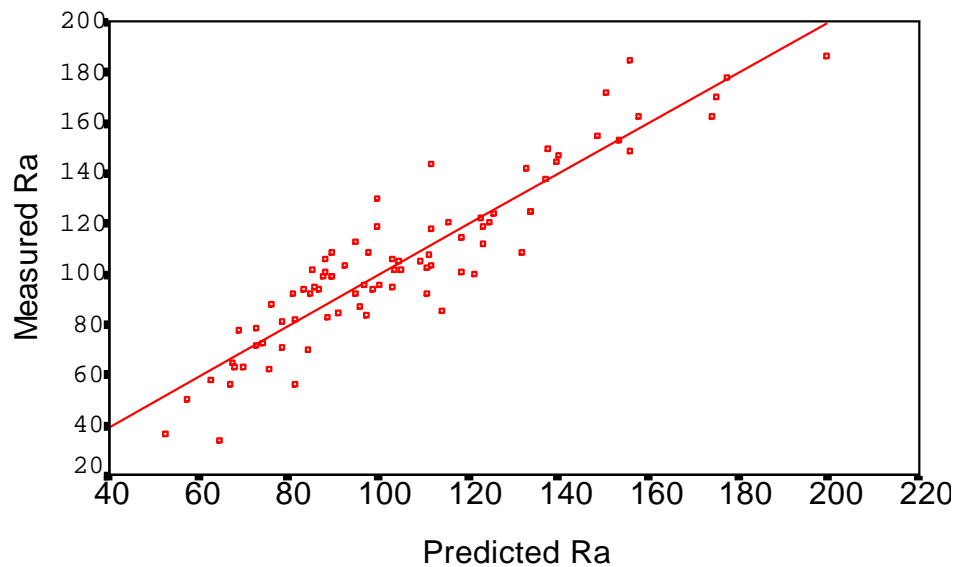

Figure 4. Scatterplot of the Measured Ra and the Predicted Ra of the Multiple Regression Prediction Model

| Model      | Sum of Square | df | Mean Square | F      | Signify. F |
|------------|---------------|----|-------------|--------|------------|
| Regression | 48742.045     | 4  | 12185.511   | 85.734 | .0000      |
| Residual   | 7817.204      | 55 | 142.130     |        |            |

Table 4. ANOVA Table

| Variable | B        | SE B       | Beta      | T      | Sig T |
|----------|----------|------------|-----------|--------|-------|
| X1X2     | -.004274 | 4.9362E-04 | -1.214506 | -8.659 | .0000 |
| X1X3     | .674909  | .210287    | .43604    | 3.209  | .0022 |
| X2       | 10.9357  | .937804    | 2.17854   | 11.661 | .0000 |
| X2X3     | -69.7694 | 15.684629  | -.684079  | -4.448 | .0000 |
| Constant | 22.9468  | 7.328064   |           | 3.131  | .0028 |

X1: Spindle Speed, X2: Feed Rate, X3: Depth of Cut (α = 0.05)

Table 5. Variable included in the Multiple Regression Equation