

Journal of

INDUSTRIAL TECHNOLOGY

Volume 16, Number 1 - November 1999 to January 2000

Integration of Product and Process Development Using Rapid Prototyping and Workcell Simulation Technologies

By Dr. Daniel Chen and Dr. Frank Cheng

KEYWORD SEARCH

**CAD
Design
Manufacturing
Materials & Processes
Quality Control**

Reviewed Article

The Official Electronic Publication of the National Association of Industrial Technology • www.nait.org

© 1999



Dr. Daniel M. Chen is currently an associate professor in the Department of Industrial and Engineering Technology at Central Michigan University. He completed his undergraduate studies at Taipei Institute of Technology, Taipei, Taiwan (1974). He also holds a M.S. from South Dakota School of Mines and Technology (1979) and a Ph.D. from Kansas State University (1984). He is a member of National Society of Industrial Technology, Society of Manufacturing Engineers, and American Society for Engineering Education. Dr. Chen has taught various courses in industrial technology and mechanical engineering technology. His current research interest is in computer-aided design. He is offering a number of courses in solid-based modeling, design, and analysis.



Dr. Frank S. Cheng is an assistant professor of the Department of Industrial and Engineering Technology (IET) at Central Michigan University (CMU). He has a M.S. degree in Mechanical Engineering (1990) and a Ph.D. in Industrial Engineering (1995) from the University of Cincinnati (UC). Since 1995, he has been actively involved in conducting teaching and research in the fields of robotics and automation at CMU. He also serves as the director of the Robotics/Automation Laboratory at CMU. His research interests are in robotic workcell design and simulation, Petri nets, flexible automation, and control system design. He is currently engaged in the project of developing teaching and research methodologies for robotic workcell design and analysis using Deneb's IGRIP robotic simulation technology.

Integration of Product and Process Development Using Rapid Prototyping and Workcell Simulation Technologies

By Dr. Daniel Chen and Dr. Frank Cheng

Introduction

In the last decade, many companies have increased their investment in computer-related technologies to reduce the time-to-market in the hope of gaining greater market share (Rehg, 1994). They have invested substantially in computer-aided design (CAD) for product design and robotic workcells for process design. Companies today experience immense pressure to provide a greater variety of complex products in shorter product development cycles. This need, coupled with a desire to further reduce costs and improve quality, has forced manufacturers to turn their focus toward the integration of product and process design activities. One possible way to achieve this goal is through the use of two current technologies, rapid prototyping and workcell simulation. The purpose of this study was to investigate the crucial roles of rapid prototyping and workcell simulation technologies in achieving the integration of product and process development. The emphasis was placed on the following two areas: (1) to establish the methodology of integration, and (2) to develop a procedure to carry out this integration.

Background Rapid Prototyping

Rapid prototyping (RP) represents a technology that quickly realizes the conceptualization of a product design (Chua & Leong, 1997 and Kochan & Chua, 1995). It provides true CAD design verification, because digital data is used directly to fabricate a cost-effective prototype. Currently, RP systems use 3D solid models directly

from CAD to build physical models with complex geometry, instead of a simplification resulting from the limitations of the fabrication method used in the traditional prototyping approaches. They can build a prototype that requires undercuts, overhangs, cores, and inner passages with high accuracy. With such a 3D prototype, designers can visualize potential problems and solutions, refining the product as early as possible in the design processes for low cost and high quality products. Use of this technology helps facilitate communication, streamline design review process, obtain meaningful feedback from different departments, and speed up the product development cycle. RP systems available today include those use the technology of fused deposition modeling (or 3D printing), stereolithography, selective laser sintering, or laminated object manufacturing.

Workcell Simulation

Industrial robots are key components to automation technology. The successful application of this technology relies heavily on how these industrial robots are strategically located and applied in workcells (Cheng & Hall, 1998 and Groover, 1986). A feature-based workcell simulation software package is ideal for this task, because it provides an interactive and accurate virtual environment with which fully integrated robotic workcells can be modeled and evaluated for low cost and reliable solutions (Rubinovitz, 1999). Designs can use the software to construct a workcell by retrieving a group of

'devices', such as robots, conveyors, workbenches, and end-effectors, etc., from built-in libraries. The software also enables users to thoroughly analyze workcell performance, optimize workcell configuration, and debug the process plan.

Major automotive companies, including Chrysler, Ford and GM, are beginning to utilize the workcell simulation software packages, such as Cimstation, Workforce and Deneb/IGRIP, for automation solutions. The greatest advantage of using the workcell simulation software is that it offers an optimum solution for the workcell design. 'Right at the first time' is a reality without having to have the physical model of parts, robots, jigs, and fixtures. Furthermore, as any modifications are made to parts, the process of incorporating the modifications into simulation is trivial compared to the process of rebuilding an actual workcell.

Methodology

3D CAD design serves as the starting point in the integration of product and process development. Once 3D CAD design has been completed, it serves as a link to utilizing both RP and workcell simulation technologies. These same technologies also serve as vital links to manufacturing processes.

3D CAD Design

For many reasons, it is important to utilize CAD software with solid modeling capabilities in the preliminary design stage. 3D CAD software defines parts as solid objects instead of either wireframe or surface models. The solid model enables the designer to easily determine part parameters such as weight and center of gravity through the software. A solid model also enables cross sectioning to expose internal details and computation of moment of inertia of cross sections. These parameters are crucial to the design evaluation of a part. The software serves as a powerful tool in design evaluation, particularly in the areas of finite element analysis and mechanism design. Finite element analysis predicts stress and deflection on a structure. It can also be used to

calculate heat transfer, fluid flow, or electrical fields, etc. Mechanism design is used to calculate geometric properties and animate mechanical mechanisms. Engineering based CAD software, which are ideal for design evaluation, include Catia, Pro-Engineer, SDRC/I-Deas, SolidWorks, and Unigraphics. Utilization of such a software package can dramatically reduce the time required for design.

Link between RP and 3 D CAD Design

A solid model of a part can be imported from a CAD system in the STL file format to a RP system. The STL file approximates the surface of the solid model by covering it with a multitude of small triangles. Then, a RP system, which uses the technology such as fused deposition modeling, builds a part with the creation process that grows the part in successive additive layers of polyester. Ideally, to make a good RP model, the STL file must be made from a watertight solid model. If the user manages to completely seal and close all corners and seams, any of the major CAD software packages mentioned above is capable of providing true solid models and consistently exporting flawless STL files. Designers can make decisions faster and iterate design changes more quickly using prototypes, saving time and energy that translates into saving dollars down the line. With a 3D model in hand, designers can easily identify costly design flaws. As a result, modifications of a part are made early in the design process before costs escalate. Detecting design flaws with prototypes complements evaluating design alternatives with engineering-based CAD software. For instance, the fit check of two mating parts, which is very difficult to evaluate on a computer, can be quickly done with prototypes.

Link between RP and Manufacturing Processes

Use of a RP system enhances the integration of design and manufacturing operations. It reduces the number of costly changes as it enhances communication between the design and manufacturing departments, giving manufacturing a chance to comment on

manufacturability and influence the product design while changes are inexpensive. The cost of a change increases roughly by an order of magnitude as the design proceeds from the significant development phase to the next (Dieter, 1991). The other advantage of linking RP to manufacturing is that the prototype of non-standard components, such as robot grippers, jigs and fixtures, may be made with polyester prototypes infiltrated with various materials to improve its strength and surface finish. Some can even be drilled, tapped, sanded, and finished in a number of ways for higher-quality models. They can be mounted on the robots and workcells for feasibility studies. At this point, the prototype of the part to be processed can also be used together with the prototypes of these non-standard components for further testing.

Link between Workcell Simulation and 3D CAD Design

Workcell simulation technology provides a crucial link between the design and manufacturing operations. Workcell simulation software usually has either input data translators, such as IGES (Initial Graphical Exchange Specification), or direct translators for the major engineering-based CAD software packages. These translators allow designers to import the file of the part to be processed from a CAD system for quick workcell design.

Figure 1 shows the procedure required for workcell design using the workcell simulation software Deneb/IGRIP. As the figure indicates, device models are the key elements that constitute a robotic workcell model. A device model is assembled by a group of 3D part models with defined coordinate systems. Standard device models, such as robots and related equipment, can be retrieved from the existing device libraries. Non-standard devices, such as jigs and fixtures, can be modeled as a group of parts on the software's built-in CAD system or imported from a standard CAD system for the workcell layout. With these precise device models, process designers can specify robot operational requirements with the choice and

number of robots and their placement in the workcell.

Workcell simulation software is also capable of evaluating the design of a workcell. The purpose is to optimize critical production factors, such as robot positioning, robot motion planning, cycle time analysis, and collision avoidance. Once a workcell model has been completed, the specified positions required for a device to move in the virtual workcell can be modeled as three-dimensional points as shown in Figure 2. Each point can be generated individually, and then snapped to a surface, edge or vertex specified in the workcell model. With the availability of the points, it is possible for designers to jog a device that has defined inverse kinematics to any point. The idea is that if the motion of a device, such as a robot, can be created graphically by positioning points on the workpiece, the software can basically simplify the programming by automatically generating programs from the graphical data of these points. The robot motion paths can also be tested and interactively edited through the built-in program editor if any potential collision is detected. By merging the realistic data from both product and workcell, users no longer base assumptions on oversimplified workcell models. Instead, users can be confident that the robot will be able to reach all of the desired locations and perform specific operations.

Link between Workcell Simulation and Manufacturing Processes

Upon the completion of both workcell design and evaluation, the manufacturing process to be carried out by the automated factory floor devices can be accurately repeated once the program is downloaded to the controllers. Existing programs can also be uploaded for evaluation and editing.

Procedure

The greatest advantage of incorporating the RP and workcell simulation technologies into the product and process development is that it eliminates the guesswork from a concept. To realize this advantage, a procedure needs to be developed in order to identify errors, evaluate alternatives,

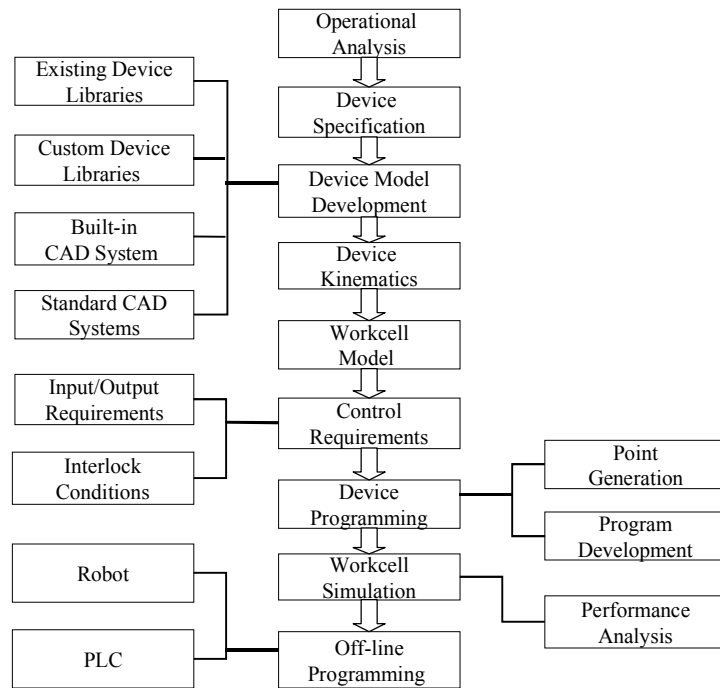

Figure 1. Flowchart of Workcell Simulation Using Deneb/IGRIP Software

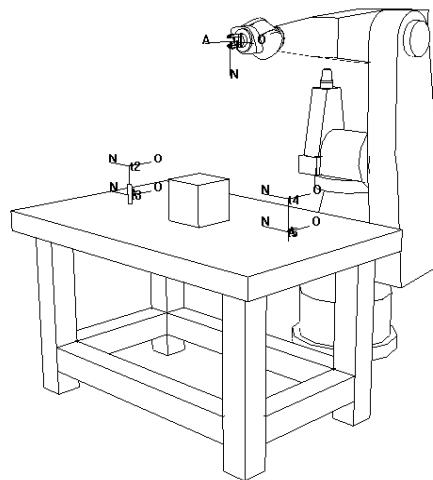

Figure 2. A Workcell Model with Three Dimensional Points

and make modifications quickly in a product development cycle. Figure 3 summarizes such a procedure. Beginning with a solid model part, there are six steps in the process linking 3D CAD design to RP, workcell simulation, and manufacturing processes.

1. Transfer the STL file from a CAD to a RP system.
2. Detect costly design flaws using the prototype.
3. Import the CAD file for workcell simulation.
4. Use the workcell simulation software for workcell design and

evaluation.

5. Provide the prototype of non-standard components, such as robot grippers, for feasibility study if necessary.
6. Download the program (as the result of step 4) for automated manufacturing processes.

Conclusion

Today, many companies have been forced to reevaluate their approach to product and process development. Although they have increased their investment, very few succeed in fully

integrating the two areas. With the implementation of RP and workcell simulation technologies, the complexity of the integration of product and process development can be significantly reduced. For manufacturers, RP and workcell simulation technologies must become the norm of the basic design phase, so the hidden cost of part and process reworks can be eliminated. Industrial technology professionals, who assume responsibilities in product design, production processes, product and process improvement, or even management, must continue to play a greater role in “how things get done”. Adopting and implementing the most current technologies to achieve the effective integration of product and process development must then be one of the priorities of industrial technology professionals.

References

Cheng, F., & Hall E. (1998). An Integrated Methodology for Product and Process Development in Automated Manufacturing Control System. *Integrated Product and Process Development: Methods, Tools, and Technologies*. John Wiley & Sons.

Chua, C. K., & Leong, K.F. (1997). *Rapid Prototyping: Principles and Applications in Manufacturing*, Wiley & Sons.

Dieter, G. (1991). *Engineering Design: A Materials and Processing Approach*. McGraw-Hill.

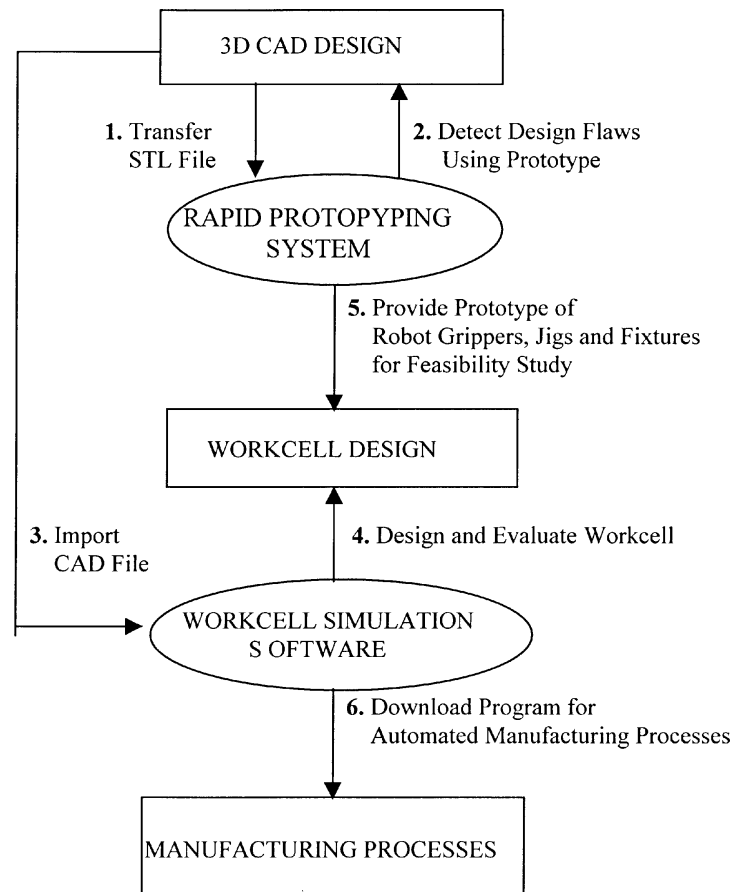

Figure 3. Procedure of Integration

Groover, M. (1986). *Industrial Robotics: Technology, Programming and Applications*. McGraw-Hill.

Kochan, D., & Chua, C.K. (1995). State-of-the-Art and Future Trends in Advanced Rapid Prototyping and

Manufacturing. *International Journal of Information Technology*, 1(2), 173-184.

Rehg, J.K. (1994). *Computer-Integrated Manufacturing*, Prentice Hall.

Rubinovitz, J. (1999). *Handbook of Industrial Robotics* (2nd Ed.). John Wiley & Sons.